

PLAN

FULL DEPTH SAW CUT THE PERIMETER

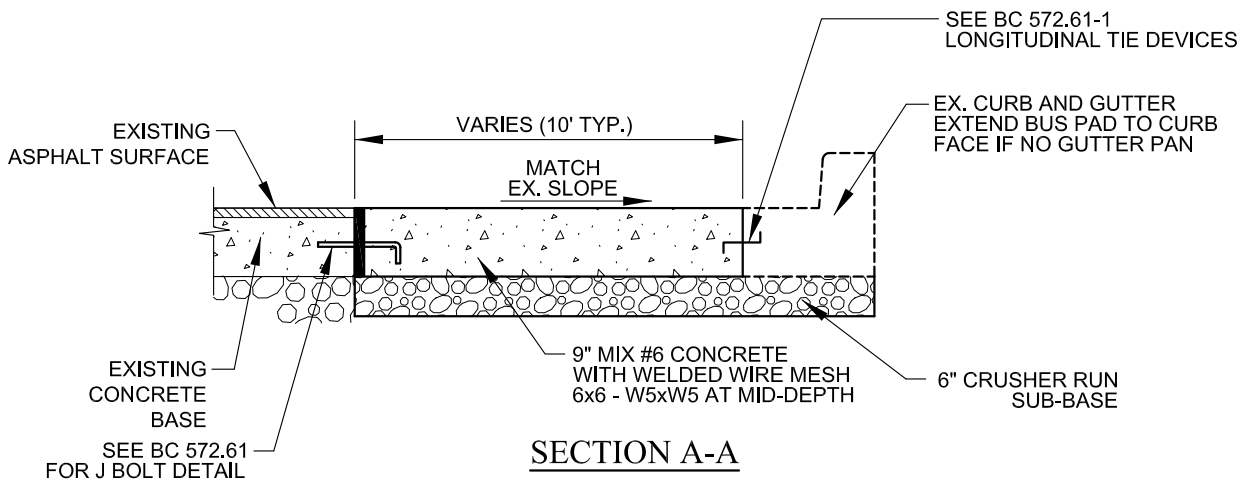

SECTION A-A

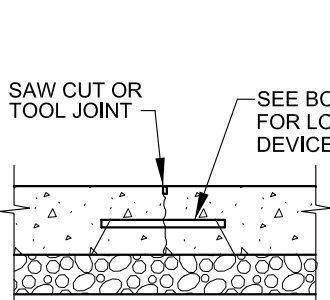

SECTION B-B

DOWELED CONTRACTION JOINT

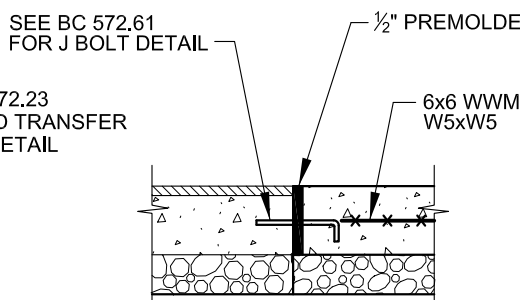

SECTION C-C

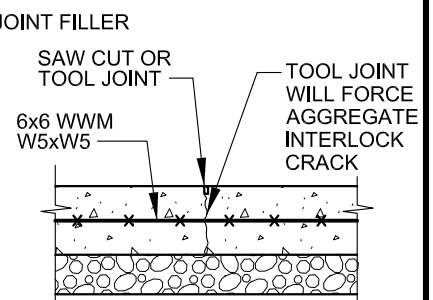

SECTION D-D

DUMMY CONTRACTION JOINT

DETAIL FOR BUS PADS ADJACENT TO RIGID PAVEMENT



APPROVED:
Primal Devita
 DIVISION CHIEF, TRANSPORTATION ENGINEERING AND CONSTRUCTION
Khalil Zare
 DIRECTOR, DEPARTMENT OF TRANSPORTATION

CITY OF BALTIMORE
 DEPARTMENT OF TRANSPORTATION
 TRANSPORTATION ENGINEERING AND CONSTRUCTION

BUS STOPPING PAD

ISSUED	REVISED	REVISED
8 / 2010		
STANDARD NO. BC 500.13-2		
SCALE: NONE	SHEET 2 OF 2	