

TEMPORARY TRAFFIC CONTROL TYPICAL APPLICATION

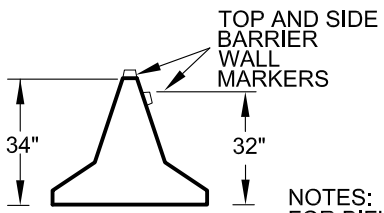

JERSEY SHAPE FRONT VIEW

NOTES:
FOR BIFURCATED JERSEY BARRIER, MAINTAIN 32 INCH HEIGHT TO TOP OF SIDE MARKER JERSEY TYPE BARRIER TO BE USED FOR REPLACEMENT PURPOSES ONLY

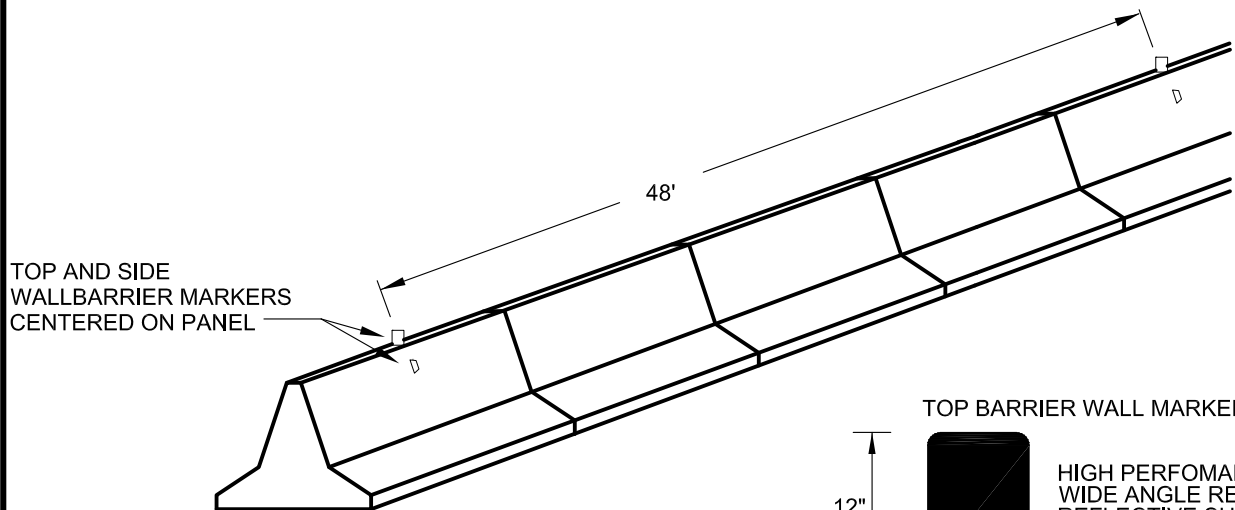
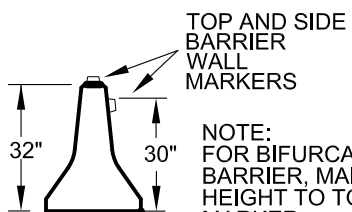

F SHAPE FRONT VIEW

NOTE:
FOR BIFURCATED F-SHAPED BARRIER, MAINTAIN 30 INCH HEIGHT TO TOP OF SIDE MARKER

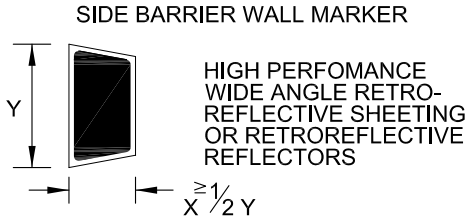
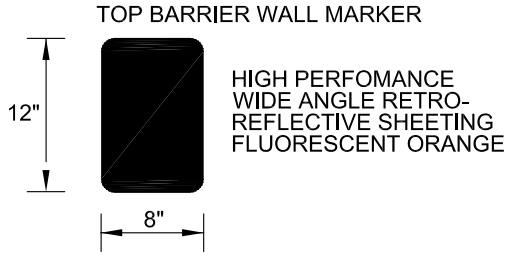

MINIMUM REFLECTIVE AREA, 7.5 SQ. IN.

NOTES:

SIDE BARRIER MARKERS SHALL BE YELLOW IN COLOR WHEN PLACED ON MEDIAN-SIDE BARRIER (SEPARATING OPPOSING TRAFFIC). SHALL BE WHITE IN COLOR WHEN PLACED ON SHOULDER-SIDE BARRIER (OR BARRIER SEPARATING SAME DIRECTION TRAFFIC).

THE SPACINGS BETWEEN MARKERS ON CURVES/TURNS SHALL BE 48 FOOT (RADIAL).

THE BOTTOM OF THE TOP MARKER SHALL BE AT THE SAME ELEVATION AS THE TOP OF THE BARRIER.

NO ATTACHMENT METHOD MAY BLOCK ANY PART OF THE REFLECTIVE AREA OF THE MARKER.

BACKING FOR TOP MARKERS SHALL BE SHEET ALUMINUM, MEETING MATERIAL THICKNESS PER TEMPORARY TRAFFIC SIGNS SPECIFICATIONS OR ANY OTHER MATERIAL APPROVED BY SHA, OFFICE OF TRAFFIC AND SAFETY.



APPROVED:

Frank Murphy

DEPUTY DIRECTOR - OPERATIONS

Khali Zae

DIRECTOR, DEPARTMENT OF TRANSPORTATION

CITY OF BALTIMORE
DEPARTMENT OF TRANSPORTATION
TRAFFIC DIVISION

**BARRIER DELINEATION
BARRIER 4' OR CLOSER TO EDGE
LINE**

ISSUED	REVISED	REVISED
8 / 2010		

STANDARD NO.
BC 104.01-6

SCALE: NONE SHEET 6 OF 7