

**PLAN**

**NOTE:**

1. ALL REINFORCING STEEL SHALL BE EPOXY COATED.

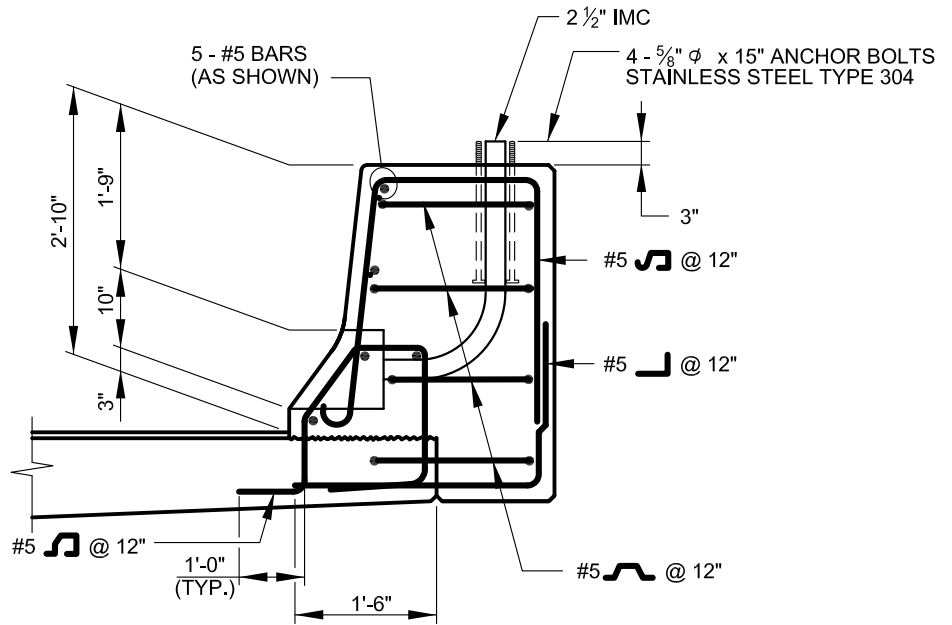

**SECTION A-A**



APPROVED:  
*Primal Devita*  
 DIVISION CHIEF, TRANSPORTATION ENGINEERING AND CONSTRUCTION  
*Khalil Zare*  
 DIRECTOR, DEPARTMENT OF TRANSPORTATION

CITY OF BALTIMORE  
 DEPARTMENT OF TRANSPORTATION  
 TRANSPORTATION ENGINEERING AND CONSTRUCTION

**EMERGENCY  
 TELEPHONE  
 SUPPORT**

ISSUED	REVISED	REVISED
8 / 2010		
<b>STANDARD NO. BC 440.05</b>		
SCALE : NONE	SHEET 1 OF 1	